

2

1

B

B

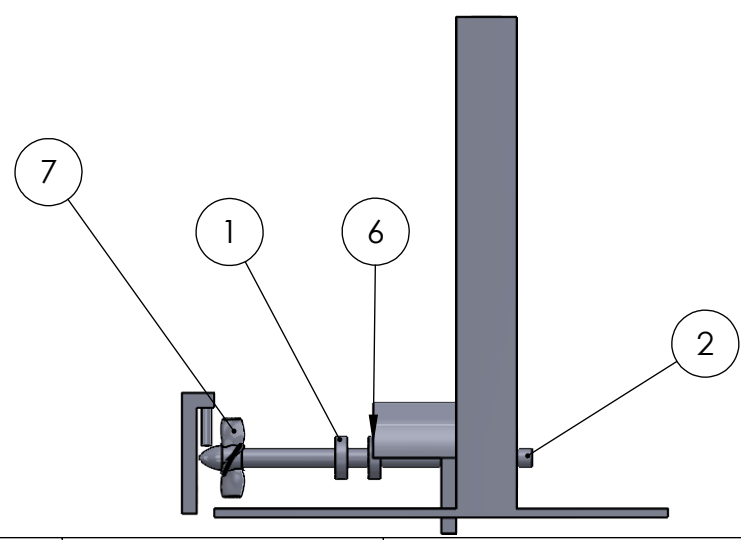
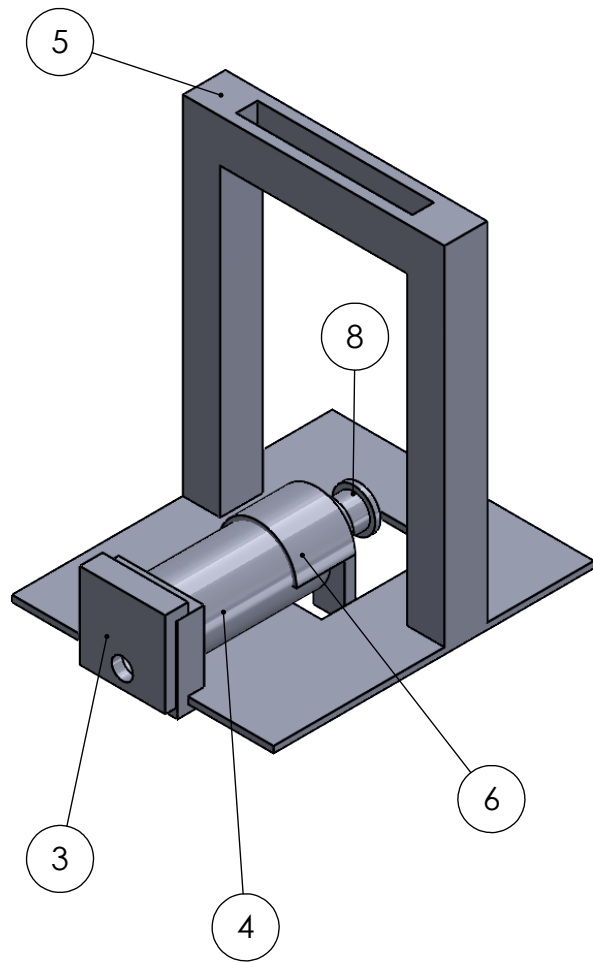

ITEM NO.	PART NUMBER	DESCRIPTION	QTY.
1	bearing	Steel (Bought)	2
2	Final Shaft	304 Stainless Steel	1
3	gate	Plastic (3D printed)	1
4	New Housing	Plastic (3D printed)	1
5	Prony Brake Stand	Wood (Plywood)	1
6	water shield	Plastic (3D printed)	1
7	Rudder	Plastic (3d printed)	1
8	3D Drum	Aluminum (machined)	1

A

A

PROPRIETARY AND CONFIDENTIAL
 THE INFORMATION CONTAINED IN THIS DRAWING IS THE SOLE PROPERTY OF <INSERT COMPANY NAME HERE>. ANY REPRODUCTION IN PART OR AS A WHOLE WITHOUT THE WRITTEN PERMISSION OF <INSERT COMPANY NAME HERE> IS PROHIBITED.

		UNLESS OTHERWISE SPECIFIED:		NAME	DATE
		DIMENSIONS ARE IN INCHES	DRAWN		
		TOLERANCES:	CHECKED		
		FRACTIONAL ±	ENG APPR.		
		ANGULAR: MACH ± BEND ±	MFG APPR.		
		TWO PLACE DECIMAL ±	Q.A.		
		THREE PLACE DECIMAL ±	COMMENTS:		
		INTERPRET GEOMETRIC TOLERANCING PER:			
		MATERIAL			
		FINISH			
NEXT ASSY	USED ON				
	APPLICATION	DO NOT SCALE DRAWING			

TITLE:		
SIZE	DWG. NO.	REV
A	BOM	
SCALE: 1:20	WEIGHT:	SHEET 1 OF 9

2

1

2

B

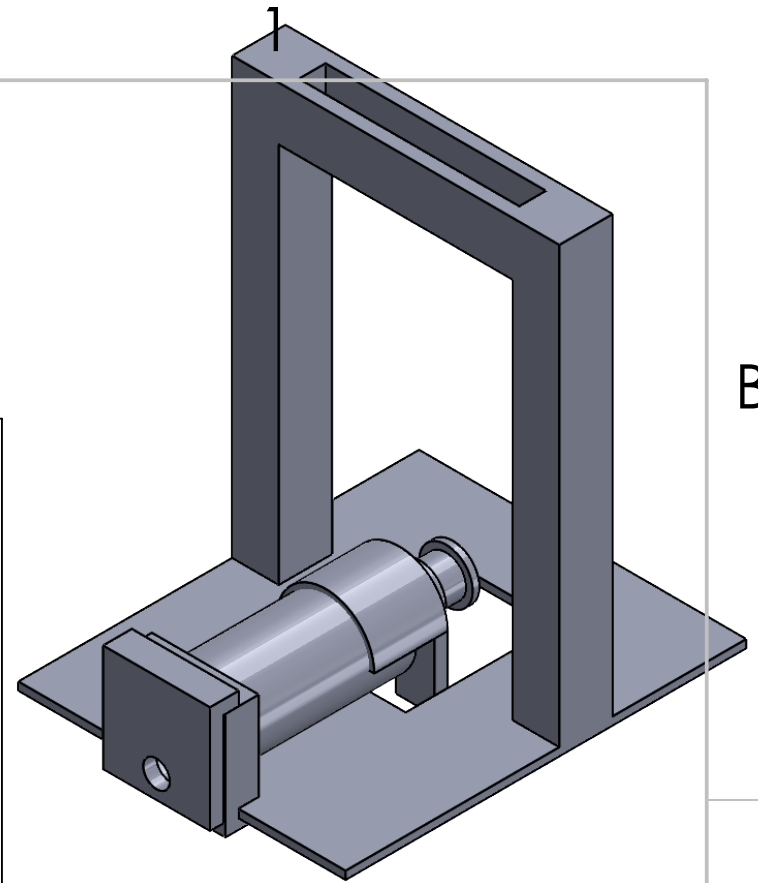
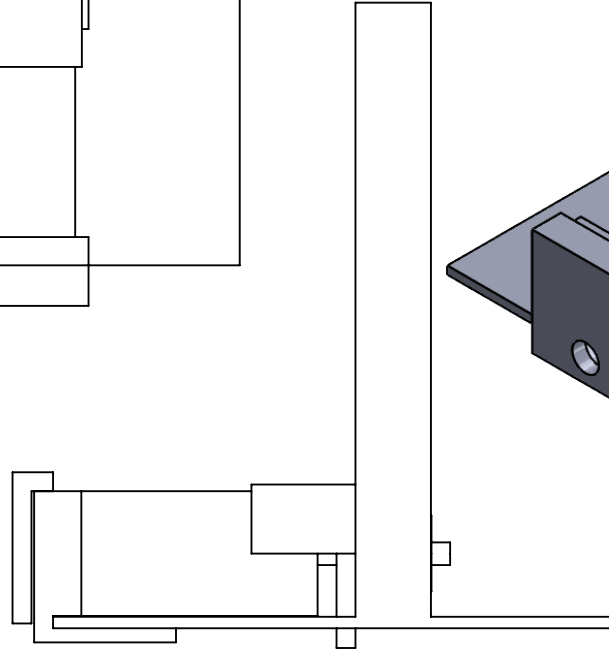
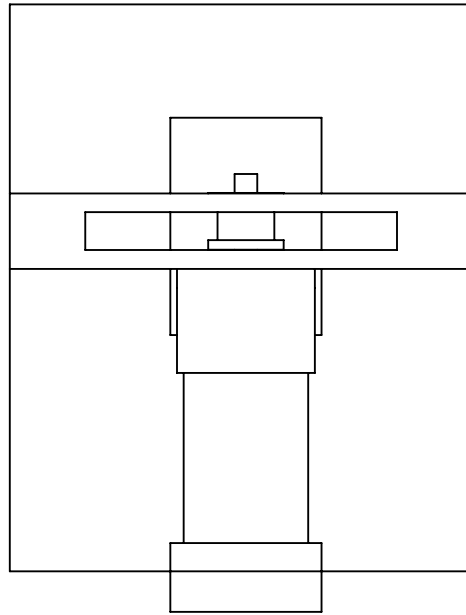
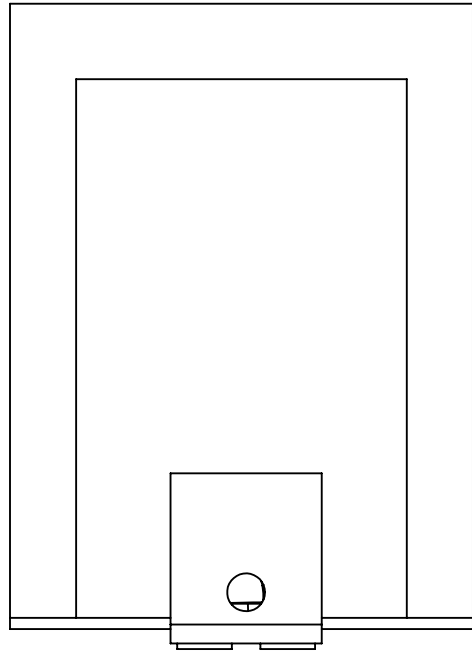

B

A

A

PROPRIETARY AND CONFIDENTIAL
 THE INFORMATION CONTAINED IN THIS DRAWING IS THE SOLE PROPERTY OF <INSERT COMPANY NAME HERE>. ANY REPRODUCTION IN PART OR AS A WHOLE WITHOUT THE WRITTEN PERMISSION OF <INSERT COMPANY NAME HERE> IS PROHIBITED.

		UNLESS OTHERWISE SPECIFIED:		NAME	DATE
		DIMENSIONS ARE IN INCHES	DRAWN		
		TOLERANCES:	CHECKED		
		FRACTIONAL \pm	ENG APPR.		
		ANGULAR: MACH \pm BEND \pm	MFG APPR.		
		TWO PLACE DECIMAL \pm	Q.A.		
		THREE PLACE DECIMAL \pm	COMMENTS:		
		INTERPRET GEOMETRIC TOLERANCING PER:			
		MATERIAL			
		FINISH			
NEXT ASSY	USED ON				
APPLICATION		DO NOT SCALE DRAWING			

TITLE:		
SIZE	DWG. NO.	REV
A	Assembly	
SCALE: 1:20	WEIGHT:	SHEET 2 OF 9

2

1

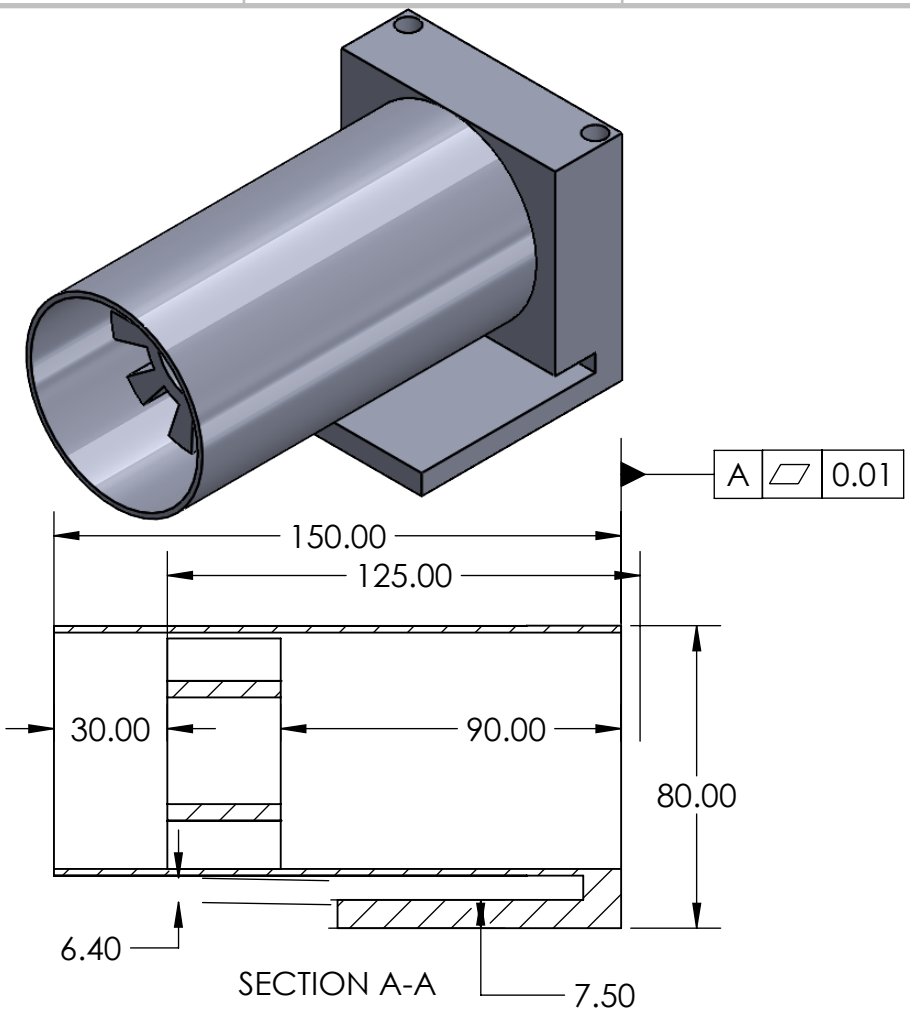
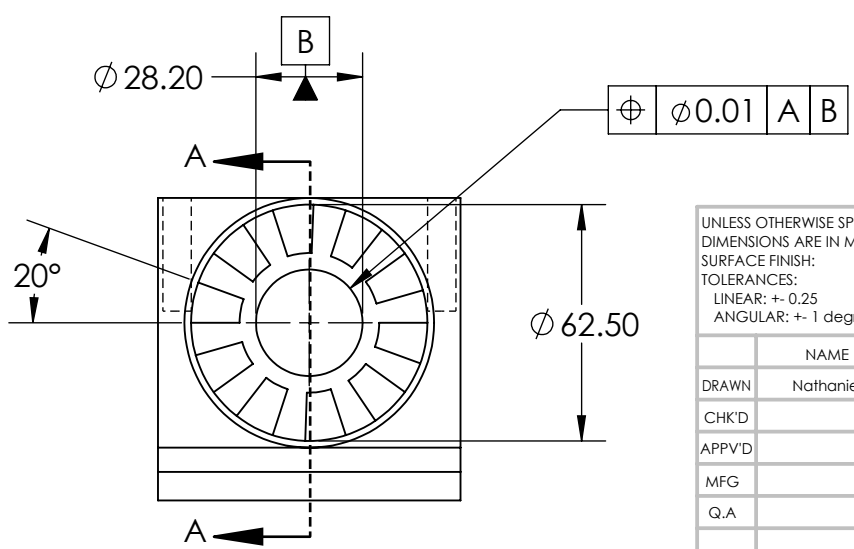
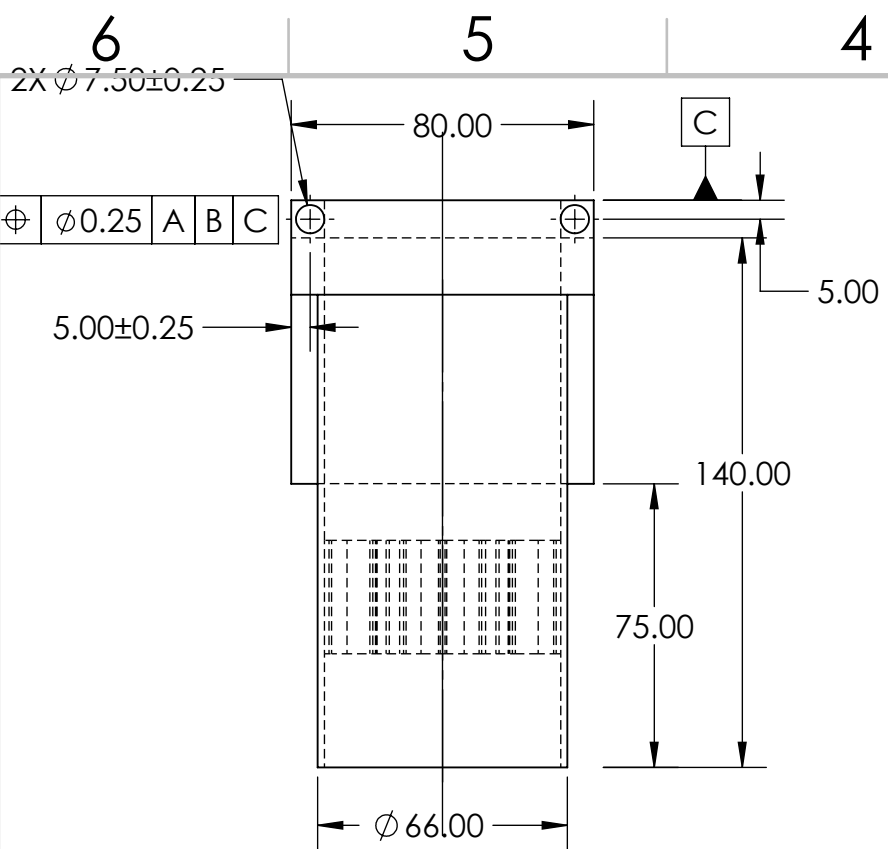

UNLESS OTHERWISE SPECIFIED: DIMENSIONS ARE IN MILLIMETERS SURFACE FINISH: TOLERANCES: LINEAR: + 0.25 ANGULAR: + 1 degree				FINISH:		DEBURR AND BREAK SHARP EDGES		DO NOT SCALE DRAWING		REVISION	
DRAWN: Nathaniel						DATE: 4/17/26		TITLE: Final Housing			
CHK'D:											
APPV'D:											
MFG:											
Q.A:						MATERIAL: Plastic		DWG NO. 4		A4	
WEIGHT:						SCALE: 1:2		SHEET 3 OF 9			

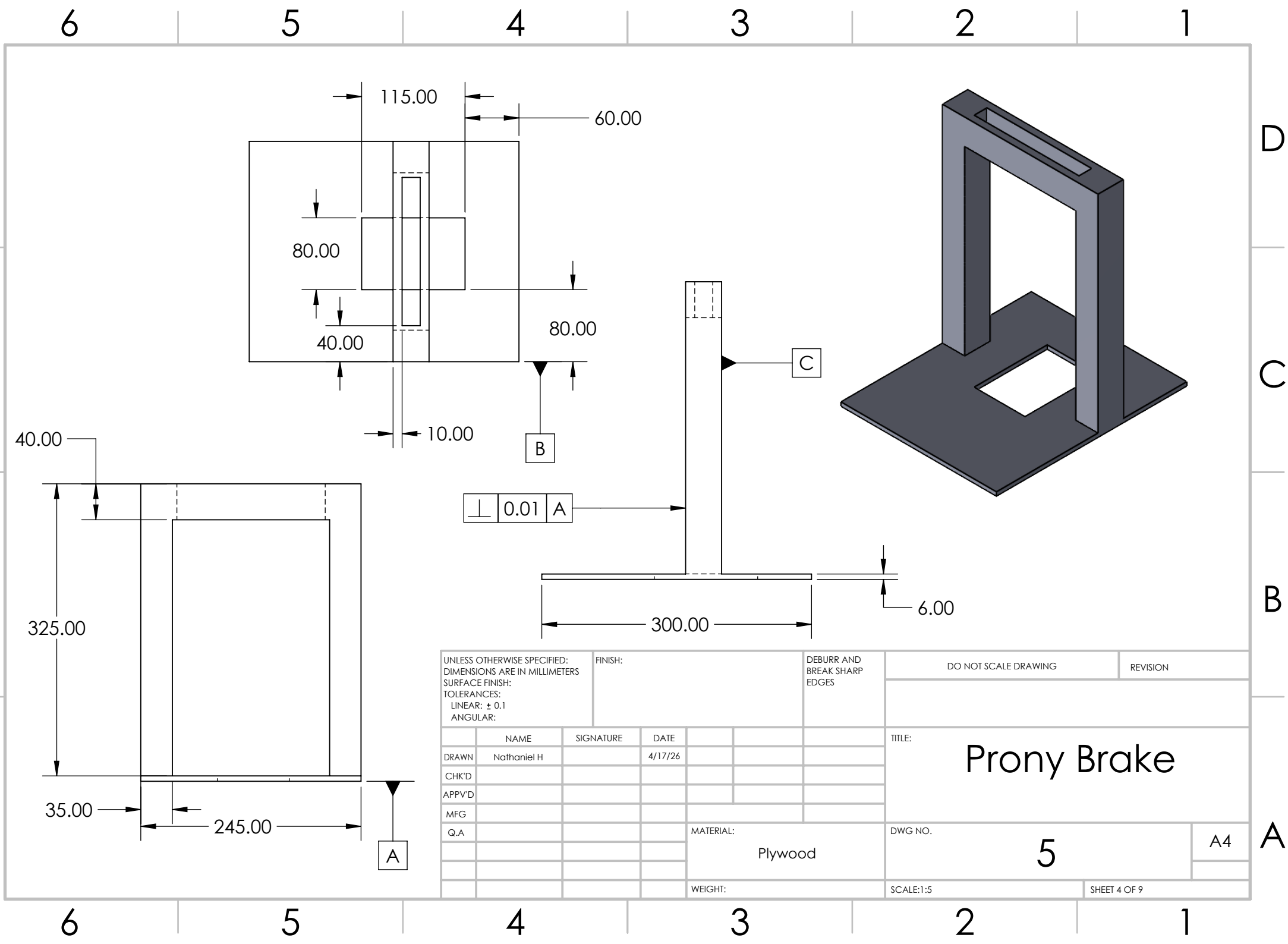

2

1

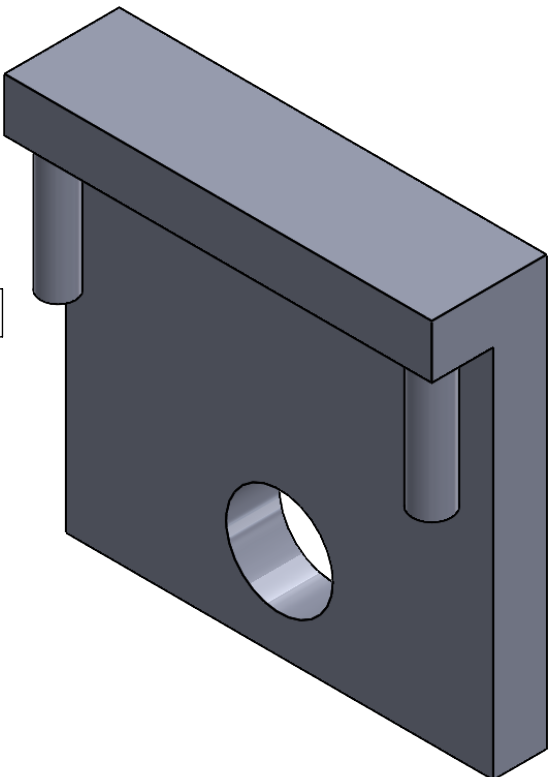
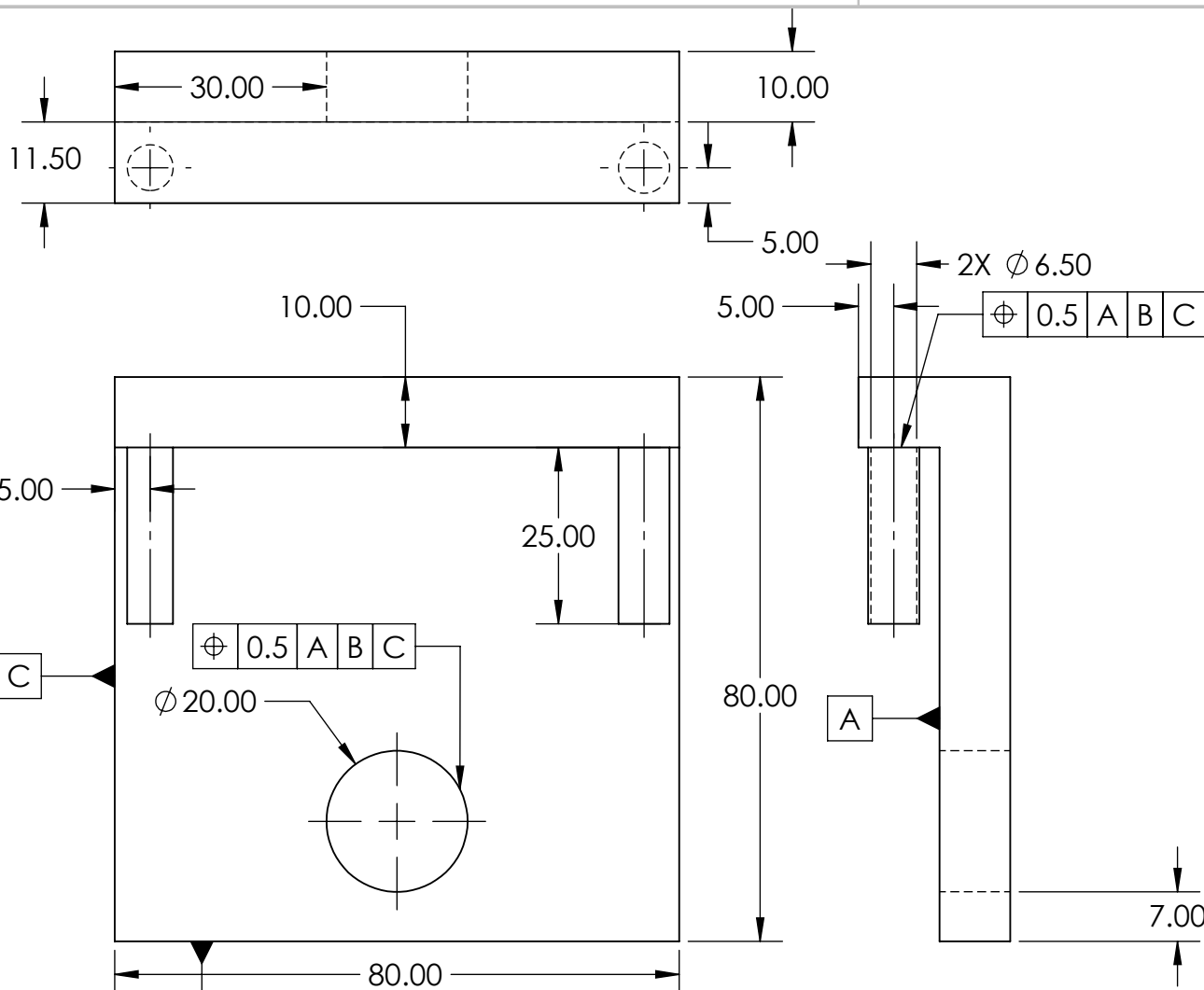

B

B

A

A

PROPRIETARY AND CONFIDENTIAL
 THE INFORMATION CONTAINED IN THIS DRAWING IS THE SOLE PROPERTY OF <INSERT COMPANY NAME HERE>. ANY REPRODUCTION IN PART OR AS A WHOLE WITHOUT THE WRITTEN PERMISSION OF <INSERT COMPANY NAME HERE> IS PROHIBITED.

		UNLESS OTHERWISE SPECIFIED:		NAME	DATE
		DIMENSIONS ARE IN INCHES	DRAWN	Nathaniel	4/17/26
		TOLERANCES: ± 0.50	CHECKED		
		FRACTIONAL \pm	ENG APPR.		
		ANGULAR: MACH \pm BEND \pm	MFG APPR.		
		TWO PLACE DECIMAL \pm	Q.A.		
		THREE PLACE DECIMAL \pm	COMMENTS:		
		INTERPRET GEOMETRIC TOLERANCING PER:			
		MATERIAL			
		Plastic			
		FINISH			
NEXT ASSY	USED ON				
APPLICATION		DO NOT SCALE DRAWING			

TITLE:		
<h1>Gate</h1>		
SIZE	DWG. NO.	REV
A	3	
SCALE: 1:1	WEIGHT:	SHEET 5 OF 9

2

1

6

5

4

3

2

1

D

D

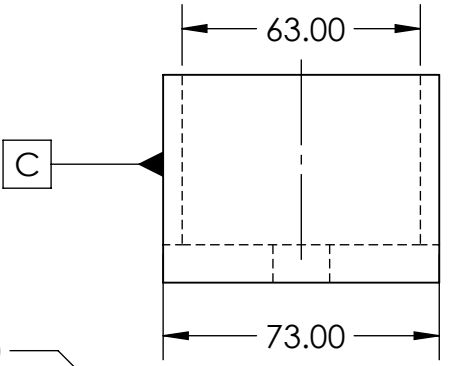
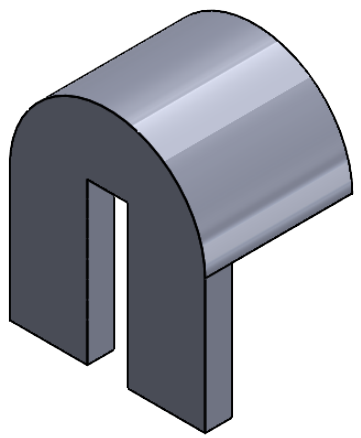

R36.50
R31.50

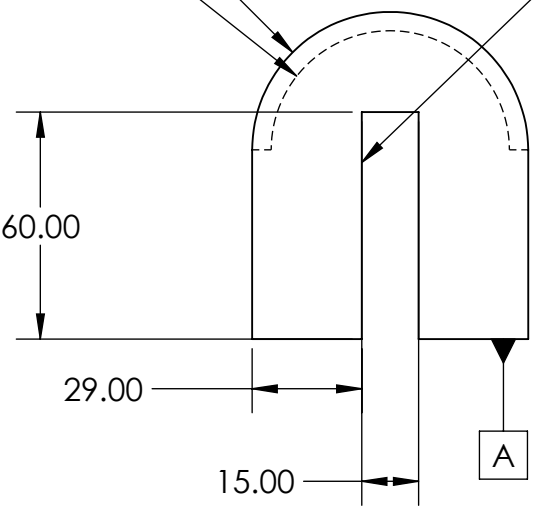

⌀ 1.00 A B C

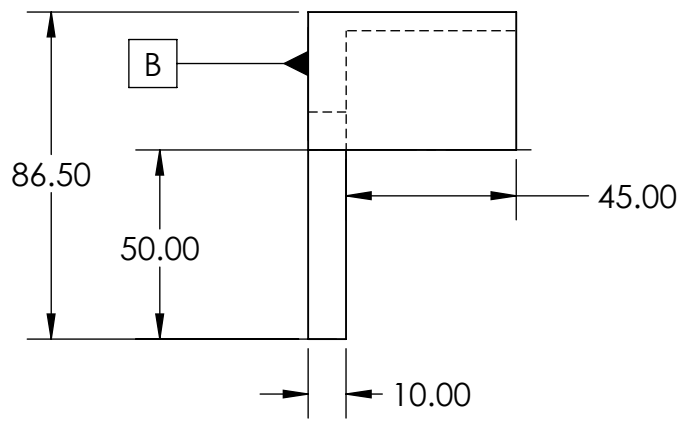

C

C

B

B

A

A

6

5

4

3

2

1

UNLESS OTHERWISE SPECIFIED: DIMENSIONS ARE IN MILLIMETERS SURFACE FINISH: TOLERANCES: LINEAR: ± 1.00 ANGULAR:			FINISH:		DEBURR AND BREAK SHARP EDGES		DO NOT SCALE DRAWING		REVISION		
DRAWN Nathaniel H			SIGNATURE		DATE 4/17/26		TITLE: <h1>Water Shield</h1>				
CHK'D											
APPV'D											
MFG											
Q.A					MATERIAL: Plastic		DWG NO. 6			A4	
					WEIGHT:		SCALE:1:2			SHEET 6 OF 9	

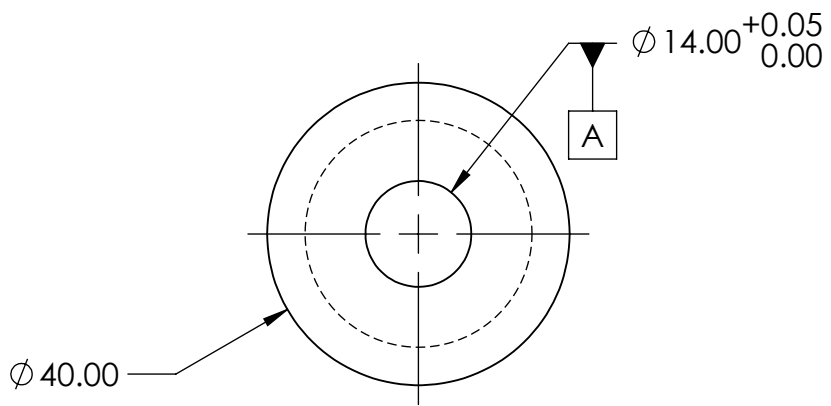
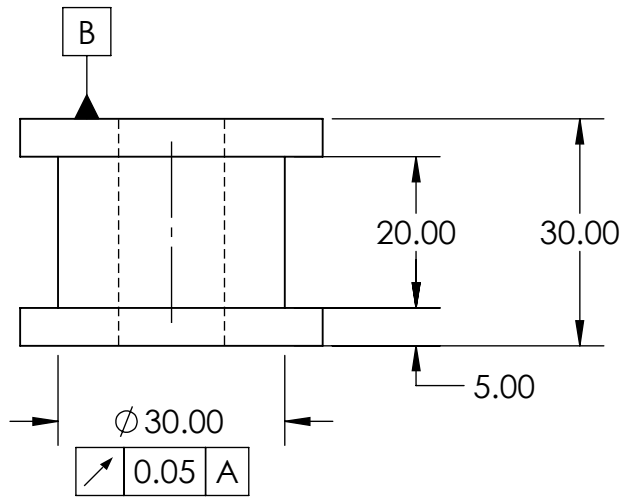
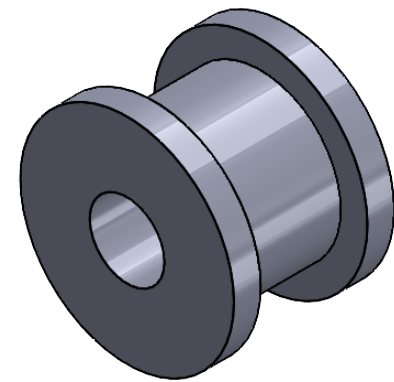

Surface finish symbol: $\sqrt{\text{0.05 A}}$

UNLESS OTHERWISE SPECIFIED: DIMENSIONS ARE IN MILLIMETERS SURFACE FINISH: TOLERANCES: LINEAR: ± 0.05 ANGULAR:				FINISH:		DEBURR AND BREAK SHARP EDGES		DO NOT SCALE DRAWING		REVISION		
DRAWN: Nathaniel H						DATE: 4/17/26						
CHK'D												
APPV'D												
MFG												
Q.A						MATERIAL: Aluminum				DWG NO. 8		A4
WEIGHT:						SCALE: 1:1				SHEET 7 OF 9		

TITLE: **Drum**

6

5

4

3

2

1

D

D

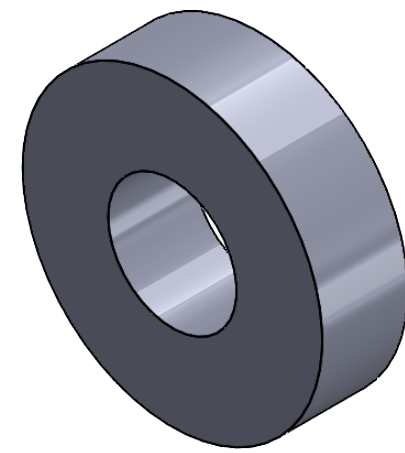
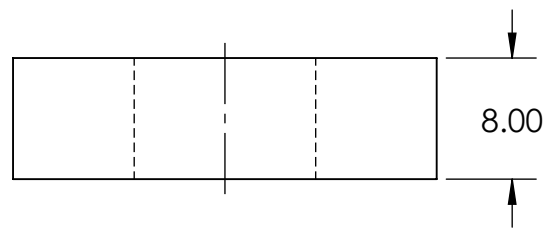

C

C

Ø 28.00

Ø 12.00

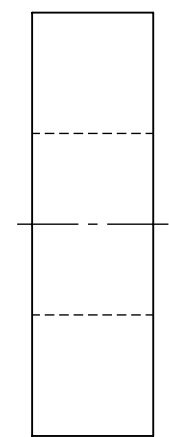
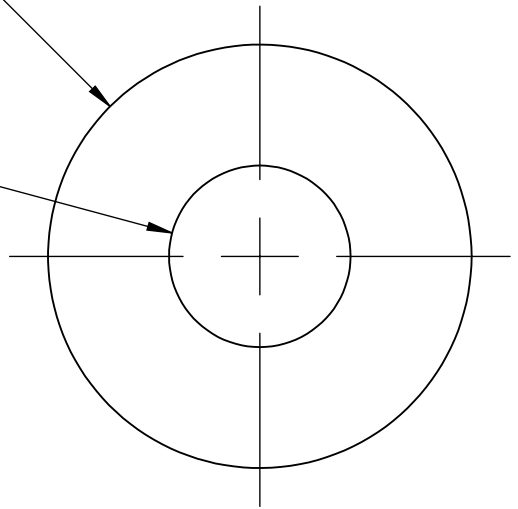

B

B

A

A

UNLESS OTHERWISE SPECIFIED: DIMENSIONS ARE IN MILLIMETERS SURFACE FINISH: TOLERANCES: LINEAR: ANGULAR:				FINISH:		DEBURR AND BREAK SHARP EDGES		DO NOT SCALE DRAWING		REVISION	
DRAWN		NAME		SIGNATURE		DATE		TITLE: <h1>Bearing</h1>			
CHK'D						4/17/26					
APPV'D											
MFG											
Q.A								MATERIAL: Steel		DWG NO. 1	
								SCALE:2:1		SHEET 8 OF 9	
										A4	

6

5

4

3

2

1

6

5

4

3

2

1

D

D

C

C

B

B

A

A

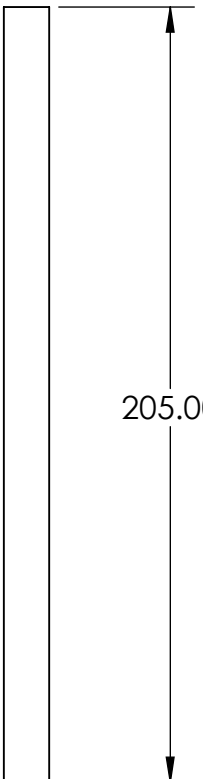

205.00

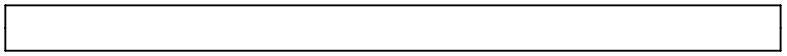
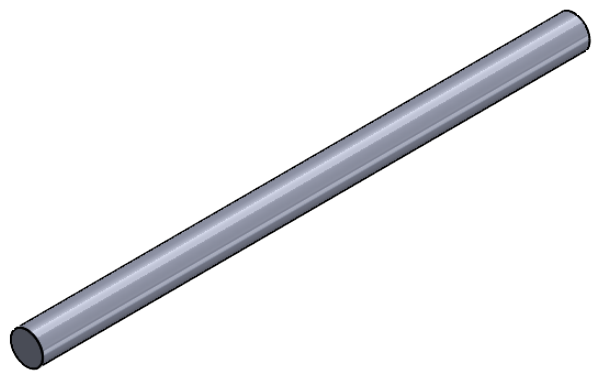

Ø 12.00^{0.00}_{-0.05}



UNLESS OTHERWISE SPECIFIED: DIMENSIONS ARE IN MILLIMETERS SURFACE FINISH: TOLERANCES: LINEAR: ± 0.05 ANGULAR:				FINISH:		DEBURR AND BREAK SHARP EDGES		DO NOT SCALE DRAWING		REVISION							
						TITLE: <h1>Shaft</h1>											
DRAWN		NAME		SIGNATURE								DATE		DWG NO.		A4	
CHK'D														2			
APPV'D																	
MFG								MATERIAL:		SCALE:1:2							
Q.A								Stainless Steel		SHEET 9 OF 9							
								WEIGHT:									

6

5

4

3

2

1